

Confidential

RSN25007F

Green Power Module (GPM)

650V 50A Inverter



Features

- 650V / 50A 3-Phase IGBT Inverter
- Low-Losses & Short-Circuit-Rated IGBTs
- Soft Reverse Recovery Diodes
- Built-In Bootstrap Diodes
- DBC Substrate
- Separate Open-Emitters from Low-Side IGBTs
- Under-Voltage Lock-Out for high side and low side
- Short-Circuit Protection
- LVIC Temperature Output
- 3.3 V and 5V Input Logic Compatible : Active High
- Fault Signaling : LVIC, UVLO and Short-circuit Protection
- Isolation Rating of 2500 Vrms/1 min
- UL Certified

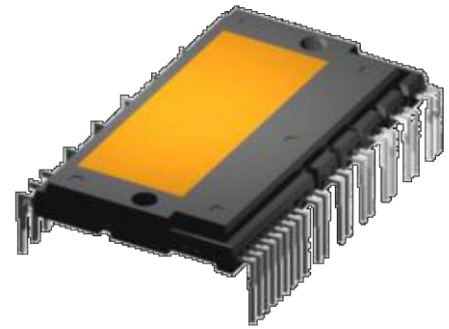

Typical Applications

- Air-conditioner, Washing machine etc.
- Motor Control – Industrial Motor (AC 200 V Class)

Confidential

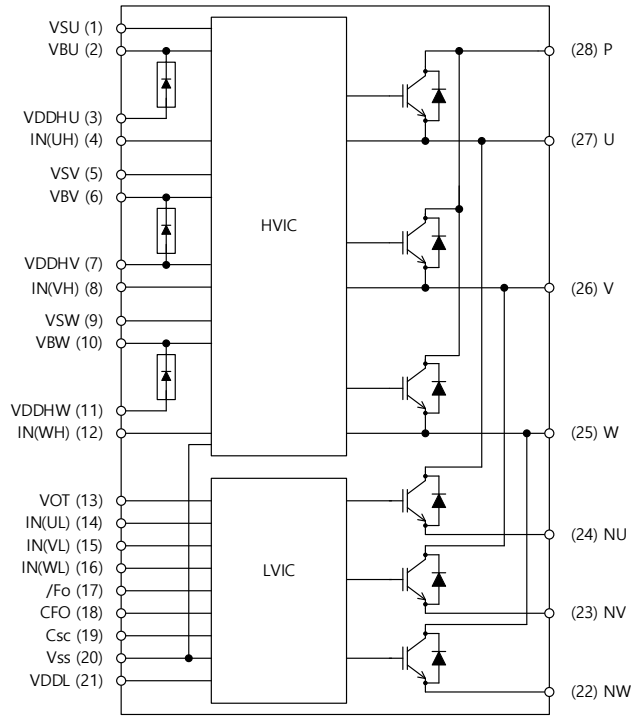
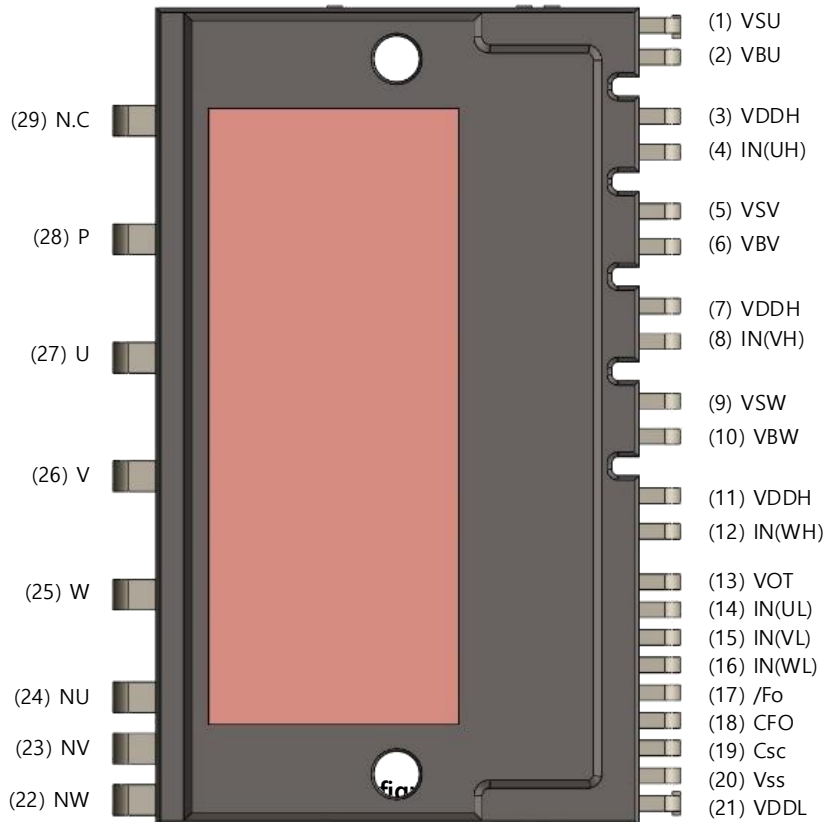

Figure 1. Internal Circuit



Confidential

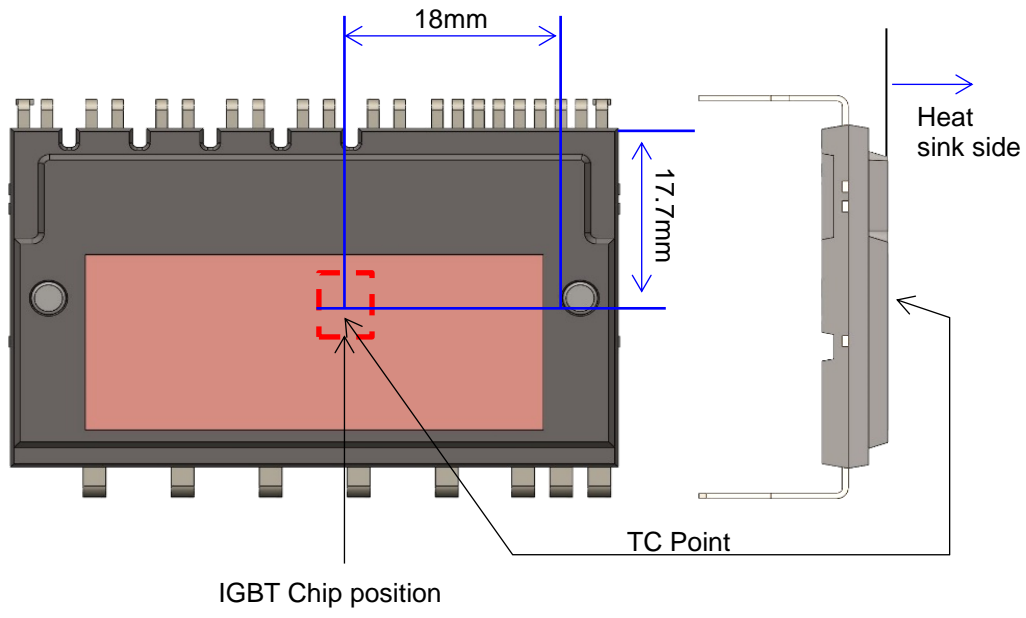

Figure 3. Tc Measurement Point

Confidential

PIN DESCRIPTION

Pin Number	Pin Name	Pin Description
1	V _{SU}	High-Side Bias Voltage Ground for U Phase IGBT Driving
2	V _{BU}	High-Side Bias Voltage for U Phase IGBT Driving
3	V _{DDHU}	High-Side Bias Voltage for U Phase Bootstrap Diode
4	IN(UH)	Signal Input for High-Side U Phase
5	V _{SV}	High-Side Bias Voltage Ground for V Phase IGBT Driving
6	V _{BV}	High-Side Bias Voltage for V Phase IGBT Driving
7	V _{DDHV}	High-Side Bias Voltage for IC and V Phase Bootstrap Diode
8	IN(VH)	Signal Input for High-Side V Phase
9	V _{SV}	High-Side Bias Voltage Ground for V Phase IGBT Driving
10	V _{BV}	High-Side Bias Voltage for V Phase IGBT Driving
11	V _{DDHV}	High-Side Bias Voltage for IC and V Phase Bootstrap Diode
12	IN(VH)	Signal Input for High-Side U Phase
13	V _{OT}	Voltage Output for LVIC Temperature
14	IN(UL)	Signal Input for Low-Side U Phase
15	IN(VL)	Signal Input for Low-Side V Phase
16	IN(WL)	Signal Input for Low-Side W Phase
17	/FO	Fault Output
18	CFO	Capacitor for Fault Output Clear Time
19	Csc	Input for Current Protection
20	V _{SS}	Low-Side Common Supply Ground, connected to LVIC
21	V _{DDL}	Low-Side Bias Voltage for IC and IGBTs Driving
22	N _W	Negative DC-Link Input for W Phase
23	N _V	Negative DC-Link Input for V Phase
24	N _U	Negative DC-Link Input for U Phase
25	W	Output for W Phase
26	V	Output for V Phase
27	U	Output for U Phase
28	P	Positive DC-Link Input
29	NC	No Connection

ABSOLUTE MAXIMUM RATINGS ($T_j = 25^\circ\text{C}$ unless otherwise noted)

Symbol	Rating	Conditions	Rating	Unit
INVERTER PART				
V_{PN}	Supply Voltage	Applied between P-N _U , N _V , N _W	450	V
$V_{PN(\text{surge})}$	Supply Voltage (Surge)	Applied between P-N _U , N _V , N _W	500	V
V_{ces}	Collector-Emitter Voltage		650	V
I_c	Each IGBT Collector Current	$T_c=25^\circ\text{C}$, $T_j \leq 150^\circ\text{C}$	50	A
I_{cp}	Each IGBT Collector Current (Peak)	$T_c=25^\circ\text{C}$, $T_j \leq 150^\circ\text{C}$, Under 1ms Pulse Width (Note 1)	100	A
P_c	Collector Dissipation	$T_c=25^\circ\text{C}$ per One Chip (Note 1)	(138)	W
T_j	Operating Junction Temperature		-40~150	$^\circ\text{C}$

CONTROL PART

V_{DD}	Control Supply Voltage	Applied between V_{DDH} , V_{DDL} - V_{SS}	20	V
V_{BS}	High-Side Control Bias Voltage	Applied between V_{BU} - V_{SU} , V_{BV} - V_{SV} , V_{BW} - V_{SW}	20	V
V_{IN}	Input Signal Voltage	Applied between IN(UH), IN(VH), IN(WH), IN(UL), IN(VL), IN(WL) - V_{SS}	-0.5~ $V_{DD}+0.5$	V
V_{FO}	Fault Output Supply Voltage	Applied between F_O - V_{SS}	-0.5~ $V_{DD}+0.5$	V
I_{FO}	Fault Output Current	Sink Current at F_O pin	5	mA
V_{sc}	Current Sensing Input Voltage	Applied between C_{sc} - V_{SS}	-0.5~ $V_{DD}+0.5$	V
T_j	Operating Junction Temperature		-40~150	$^\circ\text{C}$

BOOSTSTRAP DIODE PART

V_{RRM}	Maximum Repetitive Reverse Voltage		650	V
T_j	Operating Junction Temperature		-40~150	$^\circ\text{C}$

TOTAL SYSTEM

$V_{PN(\text{PROT})}$	Self-Protection Supply Voltage Limit (Short-Circuit Protection Capability)	$V_{DD}=V_{BS}=13.5\sim 16.5\text{V}$, $T_j=150^\circ\text{C}$, Non-Repetitive, $< 2 \mu\text{s}$	400	V
T_c	Module Case Operation Temperature	See Figure 2	-40~125	$^\circ\text{C}$
T_{stg}	Storage Temperature		-40~125	$^\circ\text{C}$
V_{iso}	Isolation Voltage	60 Hz, Sinusoidal, AC 1 Minute, Connection Pins to Heat Sink Plate	2500	Vrms

1. These values had been made an acquisition by the calculation considered to design factor.

THERMAL RESISTANCE

Symbol	Parameter	Conditions	Min	Typ	Max	Unit
$R_{th(j-c)Q}$	Junction-to-Case Thermal Resistance (Note 2)	Inverter IGBT Part (per 1/6 module)	-	-	(0.9)	$^\circ\text{C/W}$
$R_{th(j-c)F}$		Inverter FWDI Part (per 1/6 module)	-	-	(1.8)	$^\circ\text{C/W}$

2. For the measurement point of case temperature (T_c), please refer to Figure 2.

ELECTRICAL CHARACTERISTICS (T_j = 25°C unless otherwise specified.)

Symbol	Parameter	Conditions	Min	Typ	Max	Unit	
INVERTER PART							
V _{CE(sat)}	Collector-Emitter Saturation Voltage	V _{DD} =V _{BS} =15V V _{IN} =5V	I _c =50A, T _j =25°C	-	1.5	1.8	V
V _F	FWDi Forward Voltage	V _{IN} =0V	I _c =-50A, T _j =25°C	-	1.7	2.0	V
HS	Switching Times	V _{PN} =300V, V _{DD} =15 V, I _c =50A T _j =25°C V _{IN} =0V↔5V, Inductive Load, See Figure 3 (Note 3)	t _{on}		1.5		μs
			t _{c(on)}		0.2		μs
			t _{off}		1.5		μs
			t _{c(off)}		0.1		μs
			t _{rr}		0.1		μs
LS	Switching Times	V _{PN} =300V, V _{DD} =15 V, I _c =50A T _j =25°C V _{IN} =0V↔5V, Inductive Load, See Figure 3 (Note 3)	t _{on}		1.4		μs
			t _{c(on)}		0.2		μs
			t _{off}		1.4		μs
			t _{c(off)}		0.1		μs
			t _{rr}		0.1		μs
I _{ces}	Collector-Emitter Leakage Current	V _{ce} = V _{ces}	-	-	1	mA	

3. ton and toff include the propagation delay of the internal drive IC. tc(on) and tc(off) are the switching times of IGBT under the given gate-driving condition internally. For the detailed information, please see Figure 3.

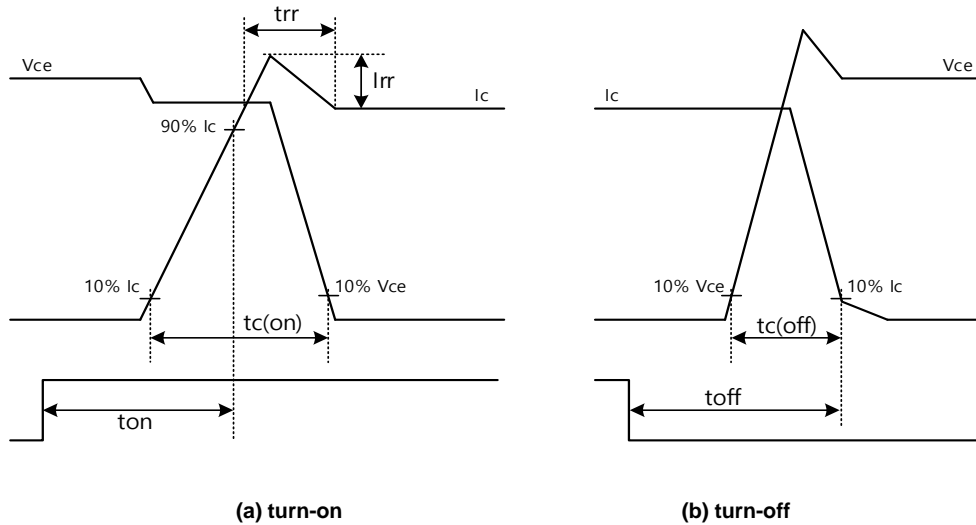

Figure 3. Switching Time Definition

Symbol	Parameter	Conditions	Min	Typ	Max	Unit	
CONTROL PART							
I _{QDDH}	Quiescent V _{DD} Supply Current	V _{DDH} =15V, V _{IN(UH,VH,WH)} =0V	V _{DDH} -V _{SS}	-	0.30	mA	
I _{QDDL}		V _{DDL} =15V, V _{IN(UL,VL,WL)} =0V	V _{DDL} -V _{SS}	-	3.40	mA	
I _{QBS}	Quiescent V _{BS} Supply Current	V _{DD} =V _{BS} =15V, V _{IN(UH,VH,WH)} =0V	V _{BU} -V _{SU} , V _{BV} -V _{SV} , V _{BW} -V _{SW}	-	0.30	mA	
V _{FOH}	Fault Output Voltage	V _{DD} =15V, V _{sc} =0V, V _{FO} Circuit: 10kΩ to 5V Pull-up		4.90	-	V	
V _{FOL}		V _{DD} =15V, V _{sc} =1V, I _{FO} =1mA		-	-	0.95	V
V _{SC(ref)}	Short Circuit Trip Level	V _{DDH} =V _{DDL} =15V	C _{SC} -V _{SS}	0.455	0.48	0.505	V

ELECTRICAL CHARACTERISTICS ($T_j = 25^\circ\text{C}$ unless otherwise specified.) (continued)

Symbol	Parameter	Conditions	Min	Typ	Max	Unit
CONTROL PART						
U_{VDD}	Supply Circuit Under-Voltage Protection	Detection Level	10.3	-	12.5	V
U_{VDDR}		Reset Level	10.8	-	13.0	V
U_{VBSD}		Detection Level	10.0	-	12.0	V
U_{VBSR}		Reset Level	10.5	-	12.5	V
$V_{IN(ON)}$	ON Threshold Voltage	Applied between $V_{IN(UH,VH,WH)}-V_{SS}$, $V_{IN(UL,VL,WL)}-V_{SS}$	-	-	2.6	V
$V_{IN(OFF)}$	OFF Threshold Voltage		0.8	-	-	V
V_{OT}	Voltage Output for LVIC Temperature Sensing Unit	$V_{DDL}=15\text{V}$, $T_{LVIC}=25^\circ\text{C}$ See Figure 4 and 5 (Note 5)	0.88	1.13	1.39	V
t_{FOD}	Fault-Out Pulse Width	$C_{FO}=22\text{nF}$	1.6	2.4	-	ms

- Short-circuit current protection functions only at the low-sides because the sense current is divided from main current at low-side IGBTs. Inserting the shunt resistor for monitoring the phase current at NU, NV, NW terminal, the trip level of the short-circuit current is changed.
- T_{LVIC} is LVIC temperature and V_{OT} is only for sensing temperature of LVIC and cannot shutdown IGBTs automatically. The relationship between V_{OT} voltage output and LVIC temperature is described in Figure 5. It is recommended to add a ceramic capacitor of 10 nF or more between V_{OT} and V_{SS} (Signal Ground) to make the V_{OT} more stable. Refer to the application note for this products about usage of V_{OT} .

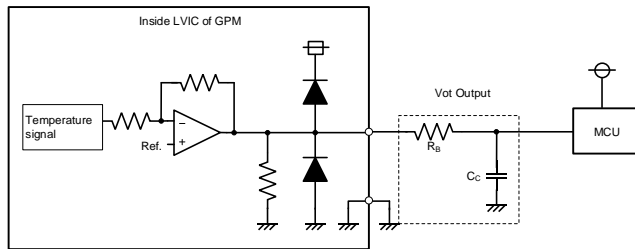

Figure 4. Internal Block Diagram and Interface Circuit of V_{OT}

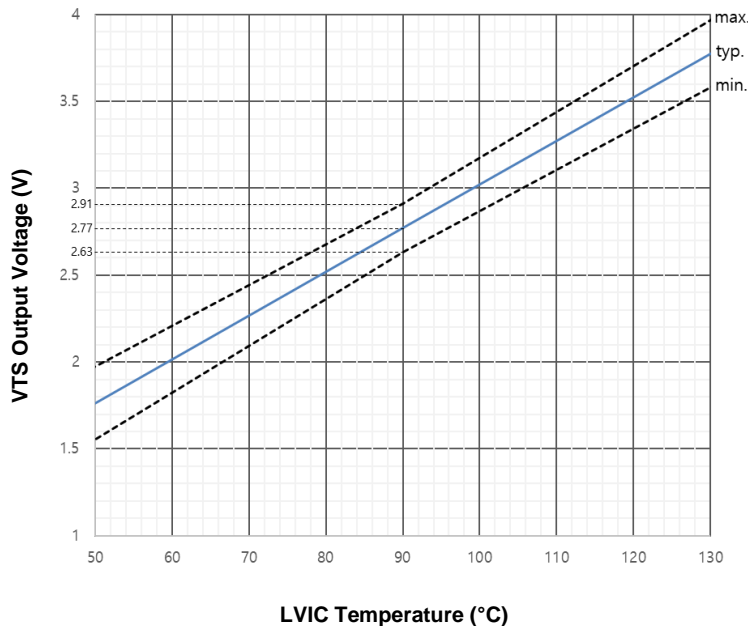

Figure 5. Temperature Profile of V_{OT}

Confidential

ELECTRICAL CHARACTERISTICS (T_j = 25°C unless otherwise specified.) (continued)

BOOTSTRAP DIODE/RESISTOR PART

Symbol	Parameter	Conditions		Min	Typ	Max	Unit
V _F	Forward Voltage	I _F =0.1A, T _j =25°C	See Figure 6	-	(1.6)	-	V

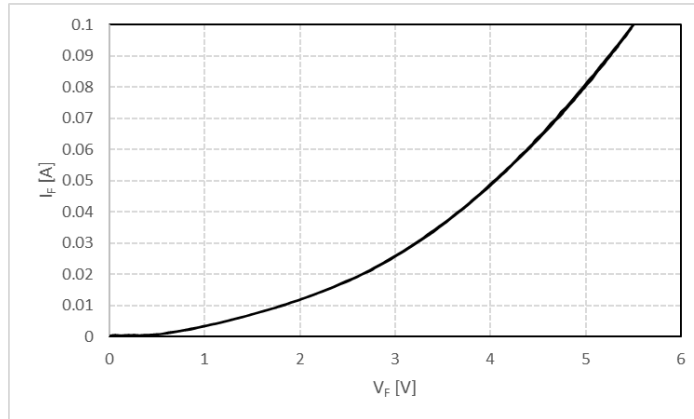

Figure 6. Characteristics of Bootstrap Diode

RECOMMENDED OPERATING RANGES

Symbol	Parameter	Conditions	Min	Typ	Max	Unit
V _{PN}	Supply Voltage	Applied between P-N _U , N _V , N _W	-	300	400	V
V _{DD}	Control Supply Voltage	Applied between V _{DDH} -V _{SS} , V _{DDL} -V _{SS}	13.5	15.0	16.5	V
V _{BS}	High-Side Control Bias Voltage	Applied between V _{BU} -V _{SU} , V _{BV} -V _{SV} , V _{BW} -V _{SW}	13.0	15.0	18.5	V
dV _{DD} /dt, dV _{BS} /dt	Control Supply Variation		-1	-	+1	V/μs
t _{dead}	Blanking Time for Preventing Arm - Short	For Each Input Signal	1.0	-	-	μs
f _{PWM}	PWM Input Signal	-40°C ≤ T _C ≤ 125°C, -40°C ≤ T _j ≤ 150°C	-	-	20	kHz
PWIN(ON)	Minimum Input Pulse Width	(Note 6)	0.7	-	-	μs
PWIN(OFF)			0.7	-	-	
T _j	Junction Temperature		-40	-	+150	°C

- This product might not make output response if input pulse width is less than the recommended value.
- RC coupling at each input might change depending on the PWM control scheme used in the application and the wiring impedance of the application's printed circuit board. The input signal section integrates 5 kΩ (typ.) pull-down resistor. Therefore, when using an external filtering resistor, please pay attention to the signal voltage drop at input terminal.

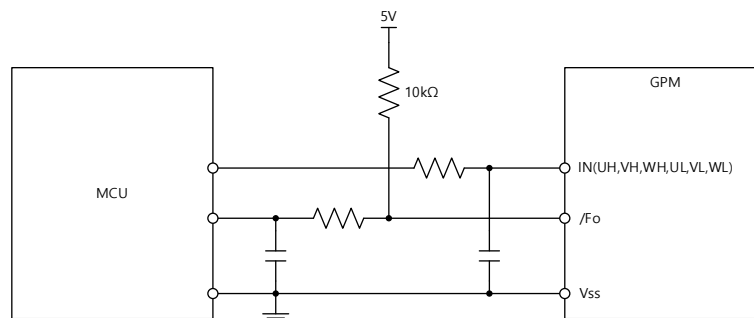

Figure 7. Recommended MCU I/O Interface Circuit

PACKAGE MARKING AND ORDERING INFORMATION

Device	Device Marking	Package	Shipping
RSN25007F	RSN25007F	GPM29-PA	400 ea/box

MECHANICAL CHARACTERISTICS AND RATINGS

Parameter	Conditions	Min	Typ	Max	Unit
Device Flatness	See Figure 8	-50	-	150	μm
Mounting Torque	Mounting Screw: M3 Recommended 1.18 N·m	0.59	0.69	0.78	N·m
Terminal Pulling Strength	Control terminal : Load 5N Power terminal : Load 10N	10	-	-	s
Terminal Bending Strength	Control terminal : Load 5N Power terminal : Load 10N 90 degree Bend	2	-	-	times
Weight		-	21	-	g

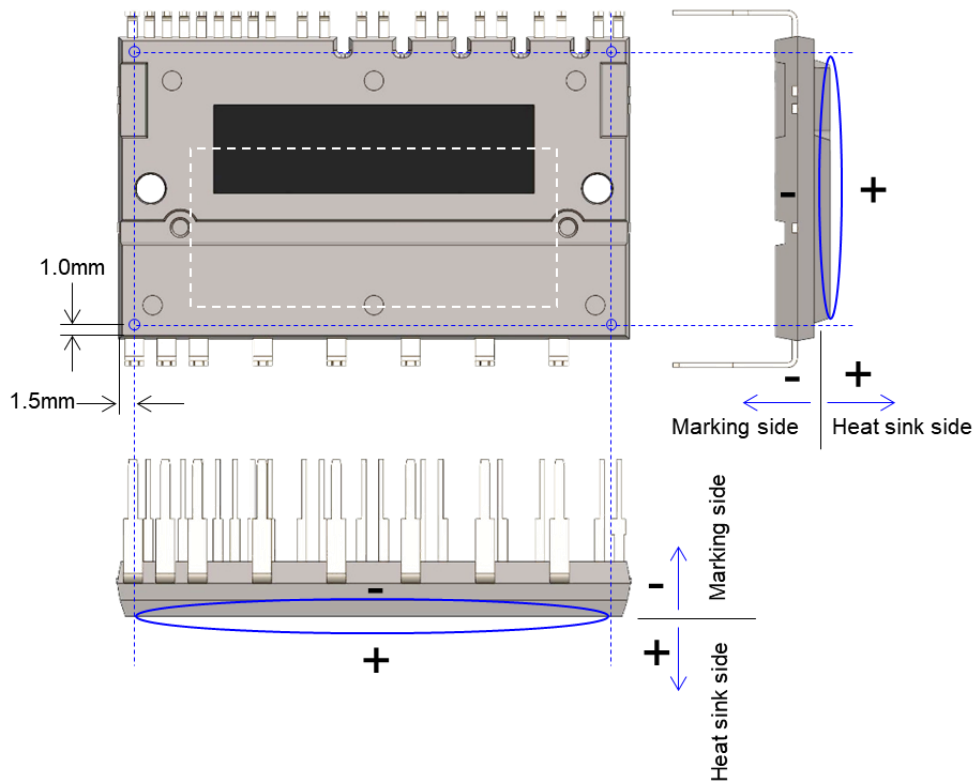
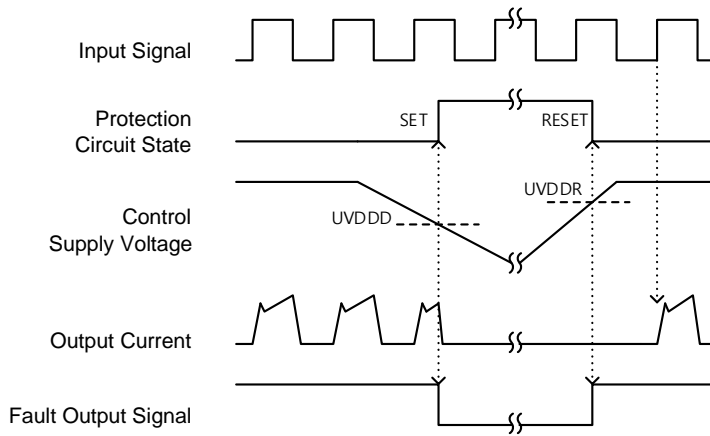

Figure 8. Flatness Measurement Position

TIME CHARTS OF SPMs PROTECTIVE FUNCTION



- a1: Normal operation: IGBT ON and carrying current.
- a2: Under-voltage detection (UVDDD).
- a3: IGBT OFF in spite of control input condition.
- a4: Fault output operation starts with a fixed pulse width.
- a5: Under-voltage reset (UVDDR).
- a6: Normal operation: IGBT ON and carrying current by triggering next signal from LOW to HIGH.

Figure 9. Under-voltage Protection (Low-side)

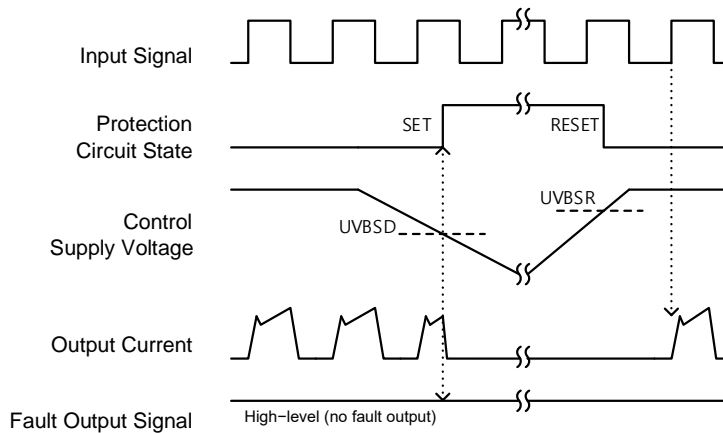

- b1: Normal operation: IGBT ON and carrying current.
- b2: Under-voltage detection (UVBSD).
- b3: IGBT OFF in spite of control input condition, but there is no fault output signal.
- b4: Under-voltage reset (UVBSR).
- b5: Normal operation: IGBT ON and carrying current by triggering next signal from LOW to HIGH.

Figure 10. Under-voltage Protection (High-side)

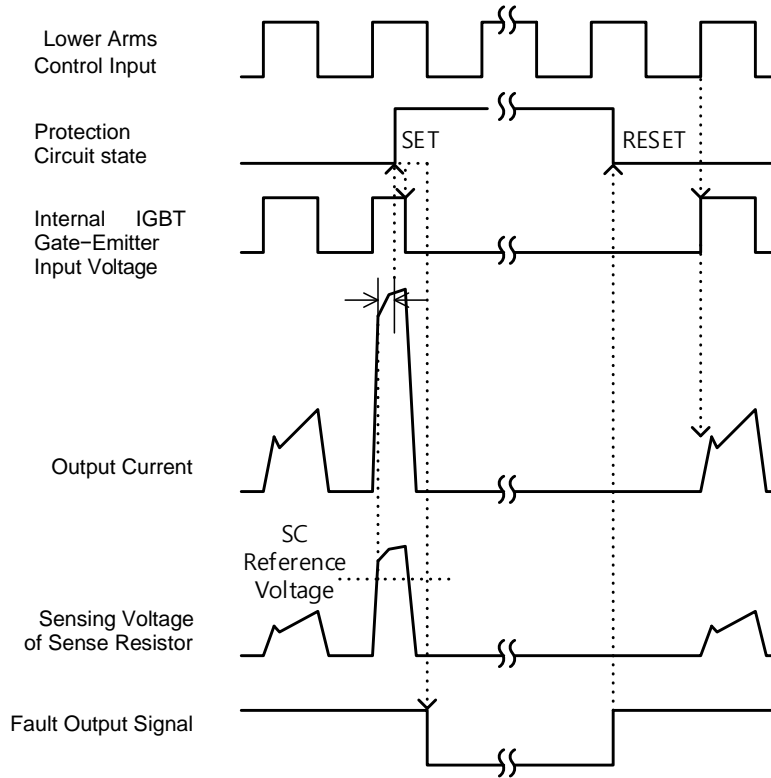

(With the external sense resistance and RC filter connection)

- c1: Normal operation: IGBT ON and carrying current.
- c2: Short-circuit current detection (SC trigger).
- c3: All low-side IGBTs gate are hard interrupted.
- c4: All low-side IGBTs turn OFF.
- c5: Fault output clear time set by the capacitance (C_{FO}).
- c6: Input HIGH – IGBT ON state, but during the active period of fault output, the IGBT doesn't turn ON.
- c7: Fault output operation finishes, but IGBT doesn't turn on until triggering the next signal from LOW to HIGH.
- c8: Normal operation: IGBT ON and carrying current.

Figure 12. Short-circuit Current Protection (Low-side Operation Only)

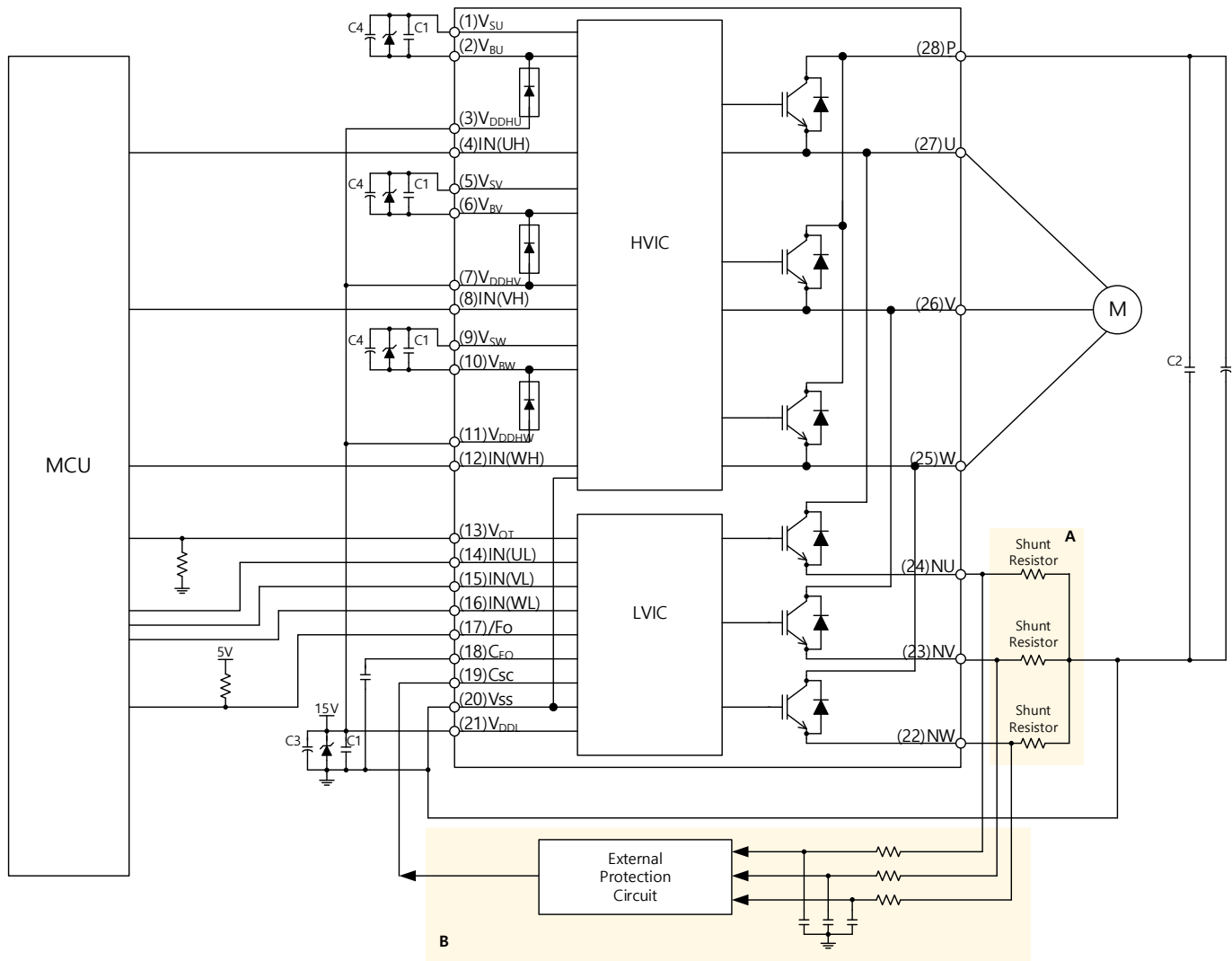

Figure 13. Typical Application Circuit

NOTES:

8. To avoid malfunction, the wiring of each input should be as short as possible (less than 2~3 cm).
9. Fault output is an open-drain type. This signal line should be pulled up to the positive side of the MCU or control power supply with a resistor that makes I_{FO} up to 1 mA. Please refer to Figure 7.
10. Input signal is active-HIGH type. There is a 5 k Ω resistor inside the IC to pull-down each input signal line to GND. RC coupling circuits should be adopted for the prevention of input signal oscillation. RC time constant should be selected in the range 50~150 ns (recommended R = 100 Ω , C = 1 nF). Please refer to Figure 7.
11. Each wiring pattern inductance of point A should be minimized (recommend less than 10 nH). Use the shunt resistor Rsh of surface mounted (SMD) type to reduce wiring inductance. To prevent malfunction, wiring of point E should be connected to the terminal of the shunt resistor R3 as close as possible.
12. To insert the shunt resistor to measure each phase current at Nu, Nv, Nw terminal, it makes to change the trip level I_{SC} about the short-circuit current.
13. To prevent errors of the protection function, the wiring of point B should be as short as possible.
14. For stable protection function, use the sense resistor Rsh with resistance variation within 1% and low inductance value.
15. In the short-circuit protection circuit, select the RC time constant of protection circuit in the range 2.0~2.5 μ s.
16. Each capacitor C1 should be mounted as close to the pins of the GPM product as possible.
17. To prevent surge destruction, the wiring between the smoothing capacitor C2 and the P & GND pins should be as short as possible. The use of a high-frequency non-inductive capacitor of around 0.1~0.22 μ F between the P & GND pins is recommended.
18. Relays are used in most systems of electrical equipment in industrial application. In these cases, there should be sufficient distance between the MCU and the relays.
19. The Zener diode or transient voltage suppressor should be adopted for the protection of ICs from the surge destruction between each pair of control supply terminals (recommended Zener diode is 22V/1W, which has the lower Zener impedance characteristic than about 15 Ω).
20. C3 of around seven times larger than bootstrap capacitor C4 is recommended.
21. Please choose the electrolytic capacitor with good temperature characteristic in C4. Choose 0.1~0.2 μ F R-category ceramic capacitors with good temperature and frequency characteristics in C1.

MECHANICAL CASE OUTLINE PACKAGE DIMENSIONS

